

-8-

-7.

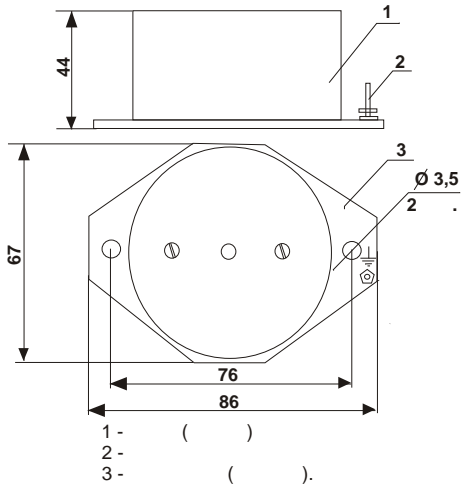

-
 " - "

- 7.

590.000.000-

Официальный представитель НПП «ТАН-ИТ»
ООО "Газкомфорт" тел (8452) 711242
 E-mail: 476338@mail.ru <http://gc64.ru>

-2-

1.

(),
 ,
 -7.

2.

(()),
 -7.

-7.

-3-

3.4. - "
 3.5. 5 250
 3.6. 5000
 3.7. 3
 3.8. : U= 220 , I= 20mA, 50
 3.9. :
 U, 5 :
 3.10. : 86 x 67 x 44

4.

-7 - 1
 - 1
 - 1
 590.000.000

5.

1/1 - ~220
 1/2 -
 2 - (2/1, 2/2 -)

0,5 5

3.

3.1. :
 --
 ...1
 3.2. (. 1)
 3.3.

- () : (-10)...(+65);
 - 80% 25° ;
 - 5...25

0.1 ;

6.

- 6.1.
- 6.2.
- 6.3.
- 6.4.

(.1)

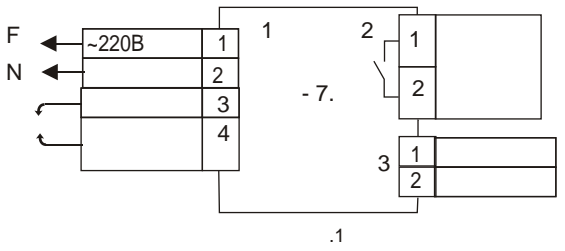

- 6.5.
- 6.6.

3 3 10-220 1mA
 (, 3,) (,)

9.

- 9.1.
- 9.2.
- 9.3.
- 9.3.

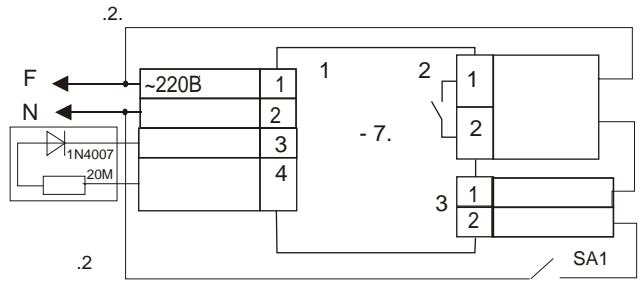

- 9.4.

SA1

7.

- 7.1. (1/4 1/3)

8.

- 8.1.
- 8.2. ()
- 8.3.
- 8.4.
- 8.5.
- 8.6. .1

27570.0-87.

10.

12 18

11.

-7, _____
 4218-006-33249750-97
 " _____ " _____ 200