

## CONFORMITY CERTIFICATE

No. 171299246

Manufacturer: **NPP «PROMA» LLC**  
**125 Tukaya Str., Kazan**  
**420054, Russia**

Product: **Flame sensor PROMA**

Type: **PROMA-FS-03M**

This conformity certificate confirms the conformity of the product with essential safety requirements of the following EC/EU New Approach Directives as amended:

**2014/30/EU EMC Directive**

European harmonized standards used for the conformity assessment:

**EN 61326-1:2013**

The certificate has been issued on the basis of the tests of the product type sample. The results are recorded in the Conformity assessment report No. 170500215 dated 13.11.2017.



mark can be used only in the case of conformity assessment according to all relevant EC/EU Directives

**This certificate is issued under the following conditions:**

1. The certificate applies to the product type and its variations specified in the above mentioned Conformity Assessment report.
2. The production process/factory production control is not covered by this certificate.
3. The certificate does not imply that the certification body has performed any surveillance or control of the production process.
4. The manufacturer shall ensure the conformity of subsequent production items with the certified type.
5. Changes that may affect the conformity with the certification requirements may make the continuation of the certificate validity dependent on the evidence as for the observance of requirements under which the certificate has been awarded, or on an additional evaluation.

Issue date: 14. 11. 2017

Expiry date: 13. 11. 2020

Issue: 1



Ing. Dušan HANKO  
Head of Product Certification Body

LIMITED LIABILITY COMPANY «PROMMASH TEST»  
Общество с ограниченной ответственностью «ПромМаш Тест»  
Testing center  
Испытательный центр

115114 Москва, Дербенёвская набережная, д.11,помещение 60

Testing laboratory of engineering products

Испытательная лаборатория продукции машиностроения

2, Simferopol highway, Tschechov, district, Tschechov, Moscow region, Russian Federation 142300

phone/fax: +7 (495) 775-48-45, add. 8090, e-mail info\_tc@prommashtest.ru

142300 Московская область, Чеховский район, г. Чехов, Симферопольское шоссе, д. 2

телефон/факс: +7 (495) 775-48-45, доб. 8090, e-mail info\_tc@prommashtest.ru



Approved  
Head of the testing laboratory:

Suharev A.V.  
08.11.2017

**TEST REPORT**  
**EN 61326-1:2013**

**Electrical equipment for measurement, control and laboratory use — EMC requirements —Part 1: General requirements**

**Report Reference No.....:053ИЛПМК-2017**

Tested by (name and signature)...: Egorov S.A.

Approved by (name and signature)...: Suharev A..V

Date of issue.....:19.06.2017

Contents.....: 32 Pages

**Testing Laboratory.....: Testing Laboratory "PromMash Test" LLC**

Address.....2, Simferopol highway, Tschechov, district, Tschechov, Moscow region, Russian Federation 142300

**Applicant's name** .....: **NPP «PROMA» LLC**

**Address**.....: **420054, Russia, Kazan, Tukaya str. 125**

**Test specification:**

**Standard**.....: **EN 61326-1:2013**

**Non-standard test method**.....:

**Test item description**.....: **Flame sensor, PROMA**

**Trademark**.....: **«PROMA»**

**Manufacturer**.....: **NPP «PROMA» LLC**

**Model/Type reference**.....: **Flame Sensor PROMA FS-03M**

**Rating(s)**.....: **24 V**

## CONTENTS

1	TEST SUMMARY .....	5
1.1	TEST FACILITY .....	5
2	GENERAL INFORMATION .....	6
2.1	GENERAL DESCRIPTION OF EUT .....	6
2.2	DESCRIPTION OF TEST MODES .....	6
2.3	DESCRIPTION TEST PERIPHERAL AND EUT PERIPHERAL .....	6
2.4	MEASUREMENT INSTRUMENTS LIST .....	7
3	EMC EMISSION TEST .....	8
3.1	CONDUCTED EMISSION MEASUREMENT .....	8
3.1.1	POWER LINE CONDUCTED EMISSION .....	8
3.1.2	TEST PROCEDURE .....	9
3.1.3	TEST SETUP .....	9
3.1.4	TEST RESULTS .....	10
3.2	RADIATED EMISSION MEASUREMENT .....	12
3.2.1	LIMITS OF RADIATED EMISSION MEASUREMENT .....	12
3.2.2	TEST PROCEDURE .....	12
3.2.3	TEST SETUP .....	12
3.2.4	TEST RESULTS .....	13
4	EMC IMMUNITY TEST .....	15
4.1	STANDARD COMPLIANCE, SEVERITY LEVEL, CRITERIA .....	15
4.2	GENERAL PERFORMANCE CRITERIA .....	16
4.3	ESD TESTING .....	17
4.3.1	TEST SPECIFICATION .....	17
4.3.2	TEST PROCEDURE .....	17
4.3.3	TEST SETUP .....	18
4.3.4	TEST RESULTS .....	19
4.3.5	PHOTO(S) SHOWN THE LOCATION(S) OF ESD EVALUATED .....	20
4.4	RS TESTING .....	21
4.4.1	TEST SPECIFICATION .....	21
4.4.2	TEST PROCEDURE .....	21
4.4.3	TEST SETUP .....	22
4.4.4	TEST RESULTS .....	22
4.5	EFT/BURST TESTING .....	23
4.5.1	TEST SPECIFICATION .....	23
4.5.2	TEST PROCEDURE .....	23
4.5.3	TEST SETUP .....	24

4.5.4	TEST RESULTS .....	25
4.6	SURGE TESTING.....	26
4.6.1	TEST SPECIFICATION .....	26
4.6.2	TEST PROCEDURE.....	26
4.6.3	TEST SETUP .....	27
4.6.4	TEST RESULTS .....	27
4.7	INJECTION CURRENT TESTING.....	28
4.7.1	TEST SPECIFICATION.....	28
4.7.2	TEST PROCEDURE.....	28
4.7.3	TEST SETUP .....	28
4.7.4	TEST RESULTS .....	29
4.8	POWER FREQUENCY MAGNETIC FIELD TESTING .....	30
4.8.1	TEST SPECIFICATION .....	30
4.8.2	TEST PROCEDURE.....	30
4.8.3	TEST SETUP .....	30
4.8.4	TEST RESULTS .....	31
5	EUT PHOTO .....	32

# 1 TEST SUMMARY

Test procedures according to the technical standards:

EMC Emission				
Standard	Test Item	Limit	Judgment	Remark
EN 61326-1:2013	Electrical equipment for measurement, control and laboratory use. EMC requirements.	Class A	PASS	Class A is for devices used in industrial electromagnetic environments
EN 55011:2009/ A1:2010	Conducted Emission	B	PASS	for Class A is used Limit A. The device also meets the limit B
	Radiated Emission	B	PASS	for Class A is used Limit A. The device also meets the limit B

EMC Imunity				
Section EN 61326-1:2013 Class A	Test Item	Performance Criteria	Judgment	Remark
EN 61000-4-2:2009	Electrostatic Discharge	B	PASS	
EN 61000-4-3:2006/ A1:2008/ A2:2010/ IS1:2009	RF electromagnetic field	A	PASS	
EN 61000-4-4:2012	Fast transients	B	PASS	
EN 61000-4-5:2006	Surges	B	PASS	
EN 61000-4-6:2014	Injected Current	A	PASS	
EN 61000-4-8:2010	Power Frequency Magnetic Field	A	PASS	
EN 61000-4-11:2004	Volt. Interruptions Volt. Dips	B/C/C/C NOTE (1)	N/A	DC Power supply

**NOTE:**

- (1) Voltage dip: 100% reduction – Performance Criteria B
- Voltage dip: 60% reduction – Performance Criteria C
- Voltage dip: 30% reduction – Performance Criteria C
- Voltage interruption – Performance Criteria C

## 1.1 TEST FACILITY

LIMITED LIABILITY COMPANY «PROMMASH TEST» Testing center

Testing laboratory of engineering products

2, Simferopol highway, Tschechov, district, Tschechov, Moscow region, Russian Federation  
142300 phone/fax: +7 (495) 775-48- 45, add. 8090, e-mail info\_tc@prommashtest.ru

## 2 GENERAL INFORMATION

### 2.1 GENERAL DESCRIPTION OF EUT

Equipment	Flame sensor
Model Name.	PROMA-FS-03M
Producer	NPP «PROMA» LLC 420054, Russia, Kazan, Tukaya str. 125
Additional Model Number(s)	----
Model Difference	----
Product Description	Flame scanner PROMA-FS-03M is a device on the basis of the microcontroller, using semi-conductor ultra-violet, infrared and visible photosensors. It is intended for selective control of flame of the main burner in multi-burner boilers with a cross firing or with close arrangement of burners where individual control of burner flames is complicated, and also for control of the general burner in a fire chamber of boilers.
Power Source	DC Voltage
Power Rating	DC from 24 to 30 V,
Consumption current:	Max 0.4 A
IP:	65

### 2.2 DESCRIPTION OF TEST MODES

To investigate the maximum EMI emission characteristics generates from EUT, the test system was pre-scanning tested base on the consideration of following EUT operation mode or test configuration mode which possible have effect on EMI emission level according to standard EN 55011.

### 2.3 DESCRIPTION TEST PERIPHERAL AND EUT PERIPHERAL

The EUT has been tested as an independent unit together with other necessary accessories or support units. The following support units or accessories were used to form a representative test configuration during the tests.

Item	Equipment	Brand	Model/Type No.	Series No.	Note
E-1	Flame sensor	N/A	PROMA-FS-03M	N/A	EUT

## 2.4 MEASUREMENT INSTRUMENTS LIST

Item	Kind of Equipment	Type No.	Register No.
1	EMI Test Receive	ESR-7	CU-090
2	LISN	ENV 432	CU-089
3	Bilog Antenna	CBL6111D	CU-103
4	AC Power Source	Net Wave 20	UO-061
5	ESD tester	Dito	UO-028
6	Signal Generator	SMT 06	UO-032
7	Power Amplifier	150W1000M1	UO-034
8	Power Amplifier	25S1G4A	UO-035
9	Surge, EFT/Burst, Voltge Interruption/DIPS Generator	UCS-500-N5	UO-072
10	Current transformer	MC-2630	UO-027
11	Injection Current Power Amplifer	CWS-500-N	UO-062
12	Coupling and Decoupling Network	CDN M2/M3	UO-065
13	Attenuator	ATT6/80	UO-064
14	Camera	HM-100	-----



### 3 EMC EMISSION TEST

#### 3.1 CONDUCTED EMISSION MEASUREMENT

##### 3.1.1 POWER LINE CONDUCTED EMISSION

(Frequency Range 9kHz-30MHz)

FREQUENCY (MHz)	Limits(dB $\mu$ V)	
	Quasi-peak	Average
0.15-0.5	66 - 56 *	56 - 46
0.50-5.0	56	46
5.0-30.0	60	50

Note:

- (1) The tighter limit applies at the band edges.
- (2) The limit of " \* " marked band means the limitation decreases linearly with the logarithm of the frequency in the range.

The following table is the setting of the receiver

Receiver Parameters	Setting
Attenuation	10 dB
Start Frequency	0.150 MHz
Stop Frequency	30 MHz
IF Bandwidth	9 kHz

### 3.1.2 TEST PROCEDURE

- a) The EUT was placed 0.8 meters from the horizontal ground plane with EUT being connected to the power mains through a line impedance stabilization network (LISN). All other support equipments powered from additional LISN(s). The LISN provide 50 Ohm/ 50uH of coupling impedance for the measuring instrument.
- b) Interconnecting cables that hang closer than 40 cm to the ground plane shall be folded back and forth in the center forming a bundle 30 to 40 cm long.
- c) I/O cables that are not connected to a peripheral shall be bundled in the center. The end of the cable may be terminated, if required, using the correct terminating impedance. The overall length shall not exceed 1 m.
- d) LISN at least 80 cm from nearest part of EUT chassis. e. For the actual test configuration, please refer to the related item -EUT Test Photos.

### 3.1.3 TEST SETUP

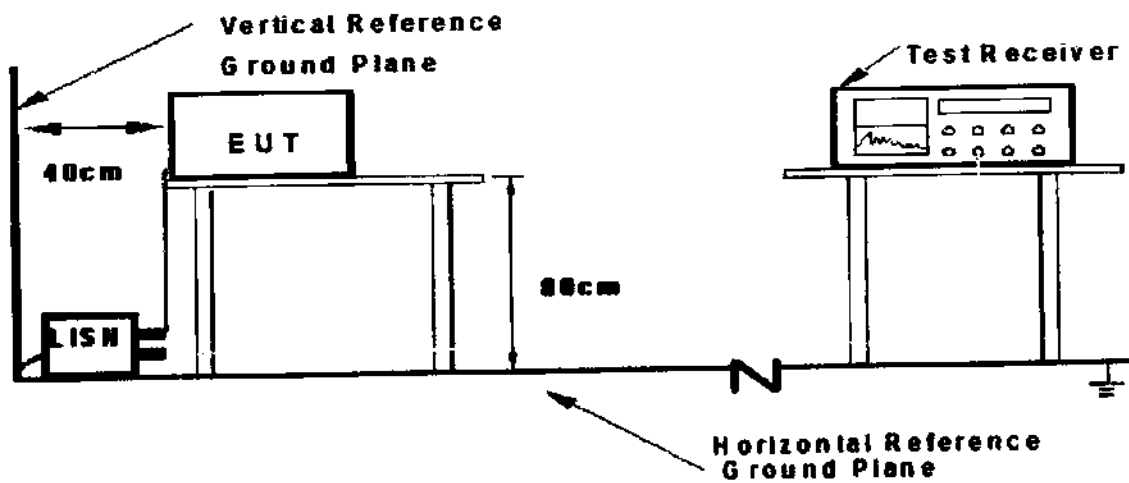

- Note: 1. Support units were connected to second LISN.**  
**2. Both of LISNs (AMN) are 80 cm from EUT and at least 80 cm from other units and other metal planes**

### 3.1.4 TEST RESULTS

EUT:	Flame sensor	Model Name:	PROMA-FS-03M
Temperature:	17°C	Relative Humidity:	62%
Pressure:	99 kPa	Date:	09.10.2017
Test Voltage:	DC 27 V	Phase:	+

Trace	Frequency	Level (dB $\mu$ V)	Phase	Detector	Delta Limit/dB
2	1.230000000 MHz	31.35		CISPR AV	-14.65
1	1.248000000 MHz	40.83		Quasi Peak	-15.17
2	1.248000000 MHz	40.78		CISPR AV	-5.22
2	3.747750000 MHz	28.64		CISPR AV	-17.36
2	18.735000000 MHz	31.09		CISPR AV	-18.91
2	28.727250000 MHz	31.77		CISPR AV	-18.23

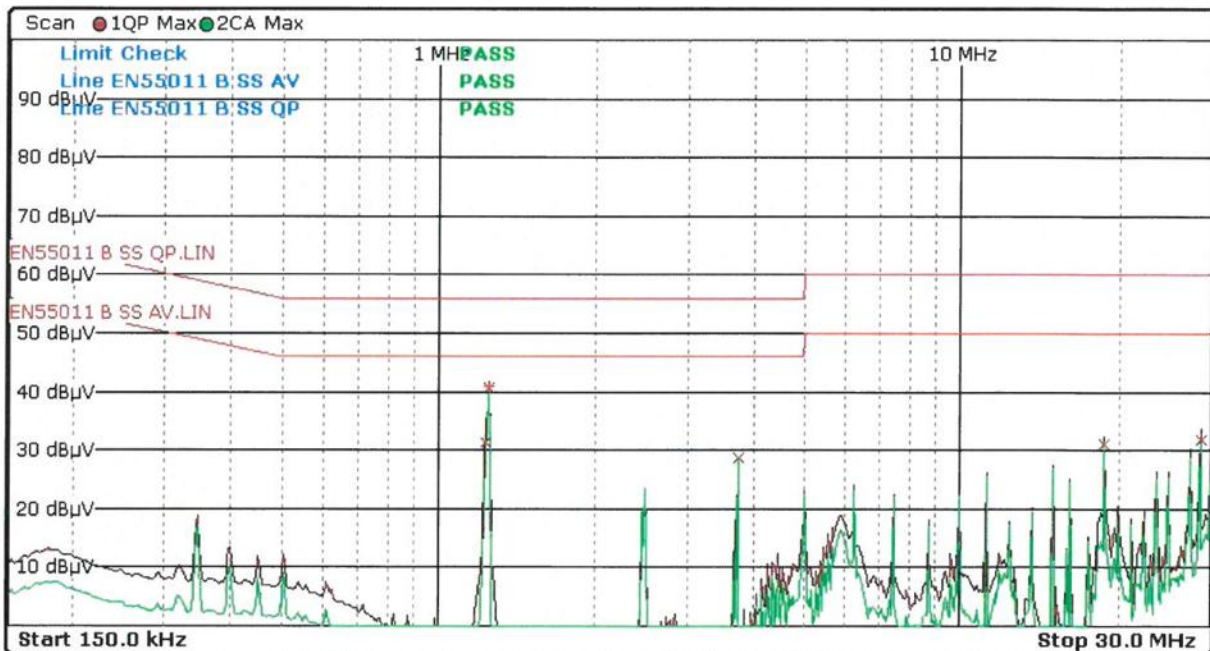

EUT:	Flame sensor	Model Name:	PROMA-FS-03M
Temperature:	17°C	Relative Humidity:	62%
Pressure:	99 kPa	Date:	09.10.2017
Test Voltage:	DC 27 V	Phase:	-

Trace	Frequency	Level (dB $\mu$ V)	Phase	Detector	Delta Limit/dB
1	1.23000000 MHz	36.34		Quasi Peak	-19.66
2	1.23000000 MHz	32.12		CISPR AV	-13.88
1	1.24800000 MHz	41.87		Quasi Peak	-14.13
2	1.24800000 MHz	41.83		CISPR AV	-4.17
2	2.49900000 MHz	35.44		CISPR AV	-10.56
2	4.99650000 MHz	27.73		CISPR AV	-18.27
2	18.73500000 MHz	31.71		CISPR AV	-18.29
2	28.72725000 MHz	31.39		CISPR AV	-18.61

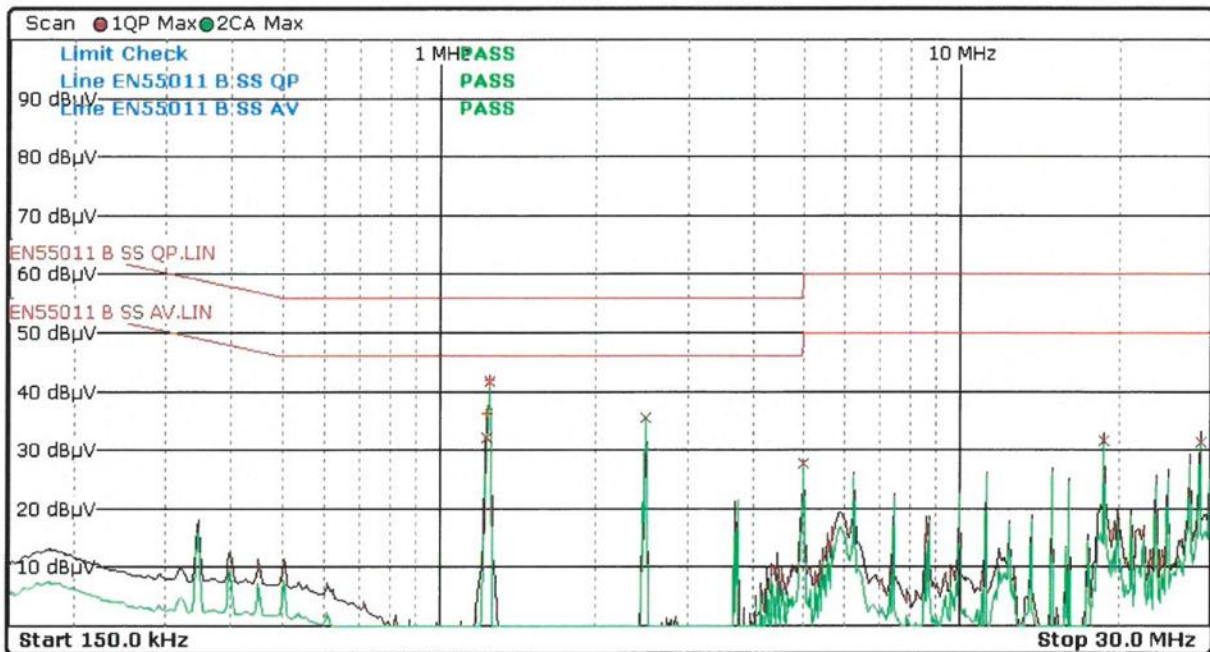

## 3.2 RADIATED EMISSION MEASUREMENT

### 3.2.1 LIMITS OF RADIATED EMISSION MEASUREMENT

FREQUENCY (MHz)	<input checked="" type="checkbox"/> at 10m	<input type="checkbox"/> at 3m
	dB $\mu$ V/m	dB $\mu$ V/m
30 to 230	30	40
230 to 1000	37	47

#### Notes:

- (1) The limit for radiated test was performed according to as following: CISPR 11.
- (2) The tighter limit applies at the band edges.
- (3) Emission level (dB $\mu$ V/m)=20log Emission level (uV/m).

### 3.2.2 TEST PROCEDURE

- a. The measuring distance of at 3 m shall be used for measurements at frequency up to 1GHz. For frequencies above 1GHz, any suitable measuring distance may be used.
- b. The EUT was placed on the top of a rotating table 0.8 meters above the ground at a 10 meter open area test site. The table was rotated 360 degrees to determine the position of the highest radiation.
- c. The height of the equipment or of the substitution antenna shall be 0.8 m; the height of the test antenna shall vary between 1 m to 4 m. Both horizontal and vertical polarizations of the antenna are set to make the measurement.
- d. The initial step in collecting conducted emission data is a spectrum analyzer peak detector mode pre-scanning the measurement frequency range. Significant peaks are then marked and then Quasi Peak detector mode re-measured, above 1G Average detector mode will be instead.
- e. If the Peak Mode measured value compliance with and lower than Quasi Peak Mode Limit, the EUT shall be deemed to meet QP(AV) Limits and then no additional QP Mode measurement performed.
- f. For the actual test configuration, please refer to the related Item –EUT Test Photos.

### 3.2.3 TEST SETUP

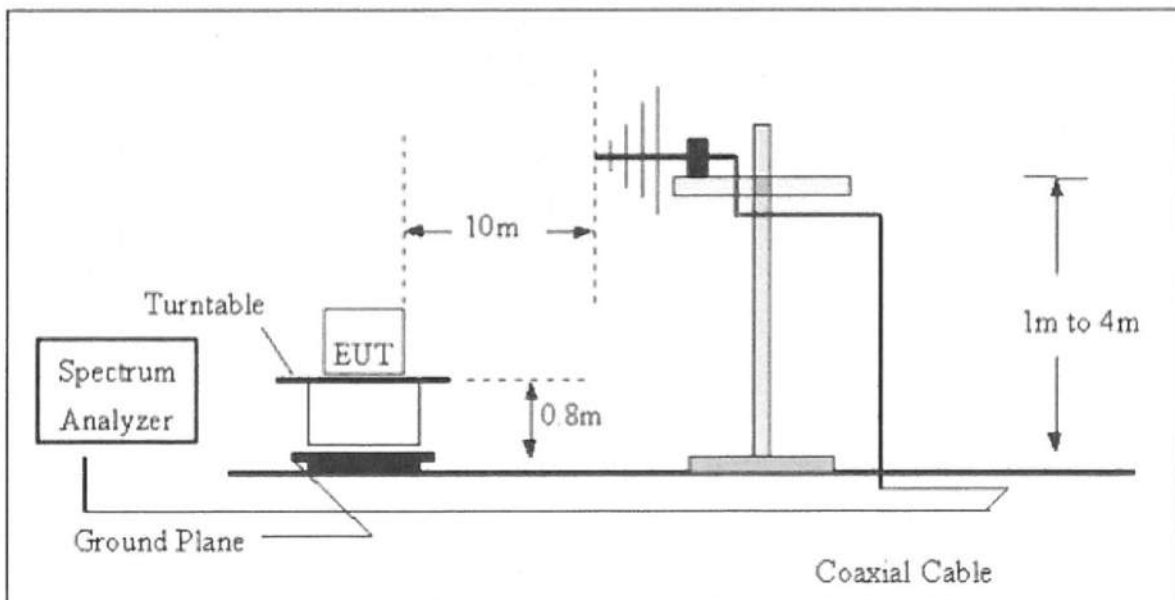

### 3.2.4 TEST RESULTS

EUT:	Flame sensor	Model Name:	PROMA-FS-03M
Temperature:	17°C	Relative Humidity:	62%
Pressure:	99 kPa	Date:	09.10.2017
Test Voltage:	DC 27 V	Polarization:	Horizontal

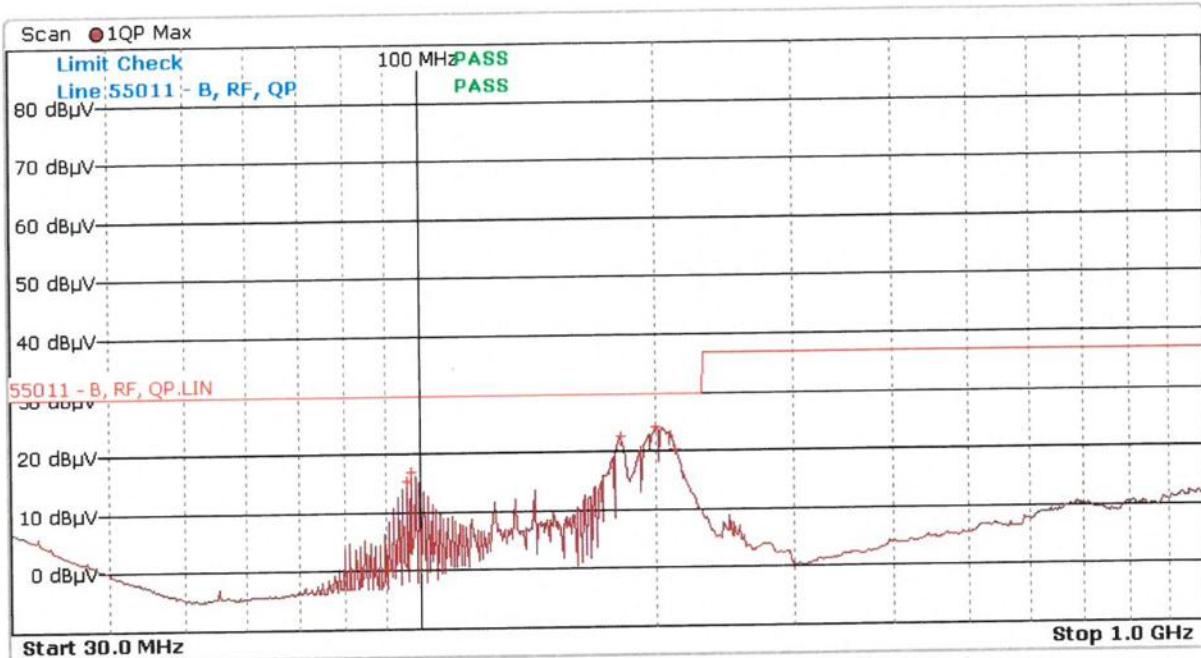

Trace	Frequency	Level (dBµV)	Phase	Detector	Delta Limit/dB
1	95.940000000 MHz	15.40		Quasi Peak	-14.60
1	97.140000000 MHz	17.05		Quasi Peak	-12.95
1	179.880000000 MHz	22.65		Quasi Peak	-7.35
1	199.860000000 MHz	24.11		Quasi Peak	-5.89
1	211.110000000 MHz	20.29		Quasi Peak	-9.71

EUT:	Flame sensor	Model Name:	PROMA-FS-03M
Temperature:	17°C	Relative Humidity:	62%
Pressure:	99 kPa	Date:	09.10.2017
Test Voltage:	DC 27 V	Polarization:	Vertical

Trace	Frequency	Level (dB $\mu$ V)	Phase	Detector	Delta Limit/dB
1	30.940000000 MHz	7.05		Quasi Peak	-22.95
1	79.140000000 MHz	7.45		Quasi Peak	-22.55
1	97.880000000 MHz	14.11		Quasi Peak	-15.89
1	140.860000000 MHz	12.65		Quasi Peak	-17.35
1	179.110000000 MHz	15.40		Quasi Peak	-14.60

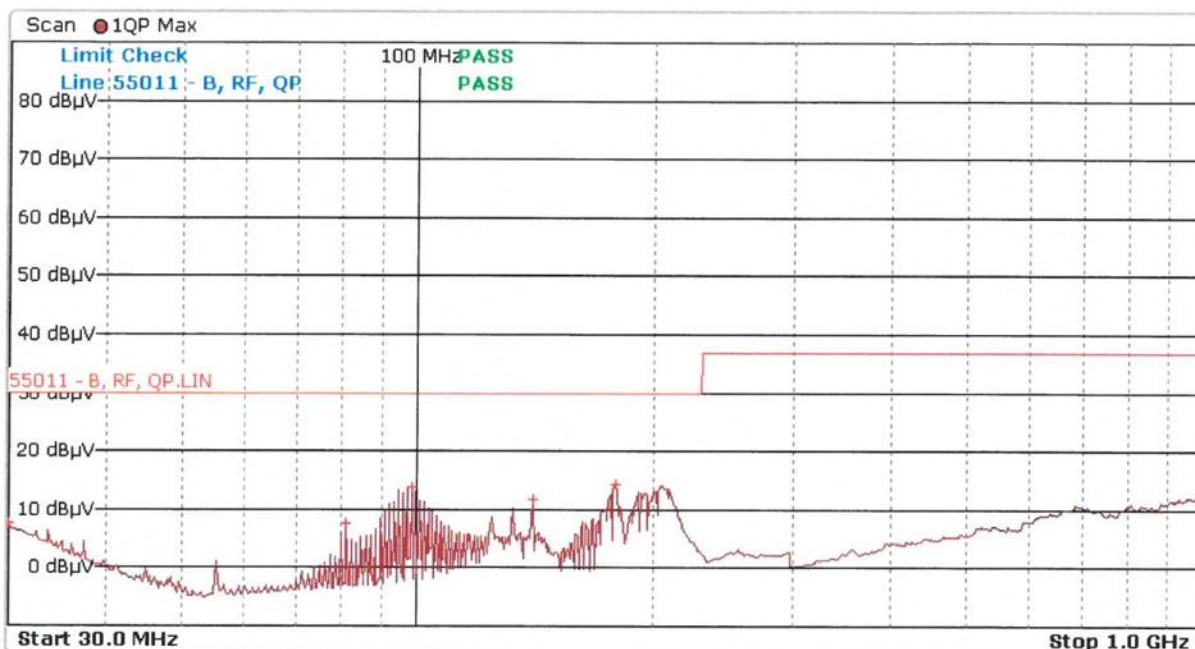

## 4 EMC IMMUNITY TEST

### 4.1 STANDARD COMPLIANCE, SEVERITY LEVEL, CRITERIA

Tests Standard No.	TEST SPECIFICATION Level	Test Mode Test Ports	Performance Criteria
<b>1. ESD</b> <b>EN 61000-4-2:2009</b>	8kV air discharge 4kV contact discharge	Direct Mode	B
	4kV HCP discharge 4kV VCP discharge	Indirect Mode	B
<b>2. RS</b> <b>EN 61000-4-3:2006/ A1:2008/ A2:2010/ IS1:2009</b>	80 MHz to 1000 MHz 1000Hz, 80%, AM modulated 10 V/m	Enclosure	A
	1400 MHz to 2000 MHz 1000Hz, 80%, AM modulated 3 V/m	Enclosure	A
	2000 MHz to 2700 MHz 1000Hz, 80%, AM modulated 1 V/m	Enclosure	A
<b>3. EFT/Burst</b> <b>EN 61000-4-4:2012</b>	5/50ns Tr/Th 5kHz Repetition Freq.	Power Supply Port	B
	5/50ns Tr/Th 5kHz Repetition Freq.	CTL/Signal Port Data Line Port	B
<b>4. Surges</b> <b>EN 61000-4-5:2006</b>	1.2/50(8/20) Tr/Th us	+/-	B
	1.2/50(8/20) Tr/Th us	+/-PE -/-PE	B
	1.2/50(8/20) Tr/Th us	CTL/Signal Port Data Line Port	B N/A Note (1)
<b>5. Injected Current</b> <b>EN 61000-4-6:2014</b>	0.15 MHz to 80 MHz, 1000Hz 80% , AM Modulated 150Ω source impedance	CTL/Signal Port Data Line Port	A N/A Note (2)
	0.15 MHz to 80 MHz, 1000Hz 80% , AM Modulated 150Ω source impedance	AC Power Port	A
	0.15 MHz to 80 MHz, 1000Hz 80% , AM Modulated 150Ω source impedance	DC Power Port	A
<b>6. Power Frequency Magnetic Field</b> <b>EN 61000-4-8:2010</b>	30 A/m 50 Hz	Enclosure	A

Note:

N/A not apply

(1) apply only if the line is longer than 30 m

(2) apply only if the line is longer than 3 m



## 4.2 GENERAL PERFORMANCE CRITERIA

According to EN 61326-1:2013 standard, the general performance criteria as following:

Criterion A	The equipment under test shall continue to operate as intended during and after the test. No degradation of performance or loss of function is allowed below a performance level specified by the manufacturer, when the equipment is used as intended. The performance level may be replaced by a permissible loss of performance. If the minimum performance level or the permissible performance loss is not specified by the manufacturer, either of these may be derived from the product description and documentation and what the user may reasonably expect from the equipment if used as intended.
Criterion B	The equipment under test shall continue to operate as intended after the test. No degradation of performance or loss of function is allowed below a performance level specified by the manufacturer, when the equipment is used as intended. The performance level may be replaced by a permissible loss of performance. During the test, degradation of performance is however allowed. No change of actual operating state or stored data is allowed. If the minimum performance level or the permissible performance loss is not specified by the manufacturer, either of these may be derived from the product description and documentation and what the user may reasonably expect from the equipment if used as intended.
Criterion C	Temporary loss of function is allowed, provided the function is self-recoverable or can be restored by the operation of the controls.

## 4.3 ESD TESTING

### 4.3.1 TEST SPECIFICATION

Basic Standard:	EN 61000-4-2
Discharge Impedance:	330ohm / 150pF
Required Performance:	B
Discharge Voltage:	Air Discharge:2kV/4kV/8kV (Direct) Contact Discharge:2kV/4kV (Direct/Indirect)
Polarity:	Positive & Negative
Number of Discharge:	Air Discharge: min. 20 times at each test point Contact Discharge: min. 20 times at each test point
Discharge Mode:	Single Discharge
Discharge Period:	1 second minimum

### 4.3.2 TEST PROCEDURE

The test generator necessary to perform direct and indirect application of discharges to the EUT in the following manner:

a. Vertical Coupling Plane (VCP):

The coupling plane, of dimensions 0.5m x 0.5m, is placed parallel to, and positioned at a distance 0.1m from, the EUT, with the Discharge Electrode touching the coupling plane. The four faces of the EUT will be performed with electrostatic discharge.

b. Horizontal Coupling Plane (HCP):

The coupling plane is placed under to the EUT. The generator shall be positioned vertically at a distance of 0.1m from the EUT, with the Discharge Electrode touching the coupling plane.

The four faces of the EUT will be performed with electrostatic discharge.

c. Air discharges at insulation surfaces of the EUT.

It was at least ten single discharges with positive and negative at the same selected point.

### 4.3.3 TEST SETUP

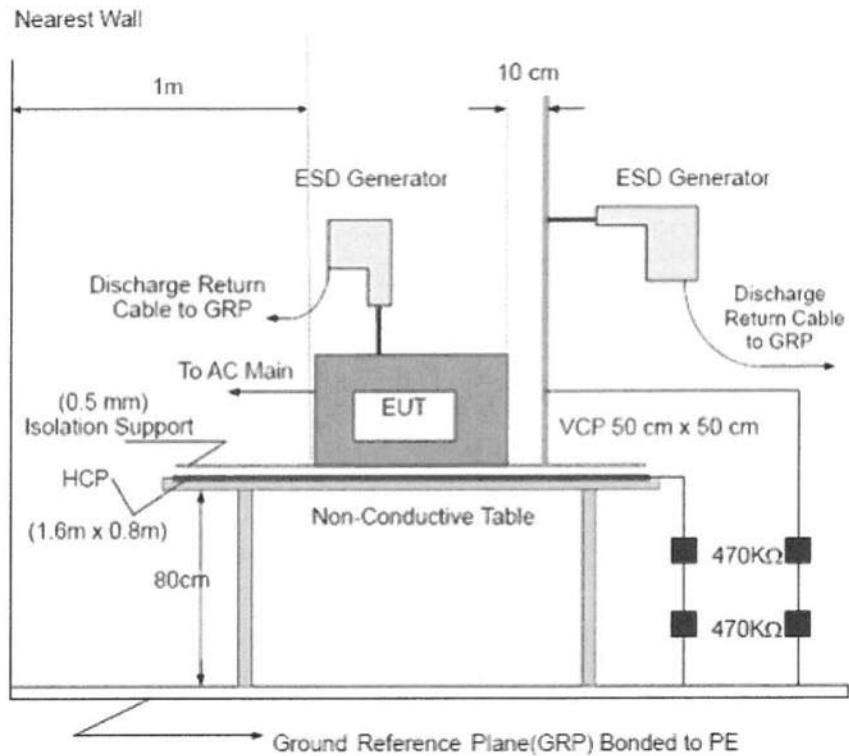

Note:

#### TABLE-TOP EQUIPMENT

The configuration consisted of a wooden table 0.8 meters high standing on the Ground Reference Plane. The GRP consisted of a sheet of aluminum at least 0.25mm thick, and 2.5 meters square connected to the protective grounding system. A Horizontal Coupling Plane (1.6m x 0.8m) was placed on the table and attached to the GRP by means of a cable with 940k total impedance. The equipment under test, was installed in a representative system as described in section 7 of IEC /EN 61000-4-2, and its cables were placed on the HCP and isolated by an insulating support of 0.5mm thickness. A distance of 1-meter minimum was provided between the EUT and the walls of the laboratory and any other metallic structure.

#### FLOOR-STANDING EQUIPMENT

The equipment under test was installed in a representative system as described in section 7 of IEC/EN 61000-4-2, and its cables were isolated from the Ground Reference Plane by an insulating support of 0.1-meter thickness. The GRP consisted of a sheet of aluminum that is at least 0.25mm thick, and 2.5meters square connected to the protective grounding system and extended at least 0.5 meters from the EUT on all sides.

### 4.3.4 TEST RESULTS

EUT:	Flame sensor	Model Name:	PROMA-FS-03M
Temperature:	17°C	Relative Humidity:	62%
Pressure:	99 kPa	Date:	09.10.2017
Test Voltage:	DC 27 V		

Mode	Contact Discharge (Indirect)							Criterion	Result
Test level (kV)	Test Point	2		4		6			
Test Location		+	-	+	-	+	-		
HCP	Front			P	P			B	Complies
	Rear			P	P				
	Left			P	P				
	Right			P	P				
VCP	Front			P	P				
	Rear			P	P				
	Left			P	P				
	Right			P	P				

Mode	Air Discharge								Contact Discharge								Criterion	Result
Test level (kV)	2		4		8		15		2		4		6		8			
Test Location	+	-	+	-	+	+	-	+	-	+	-	+	-	+	+	-		
C1											P	P						
C2											P	P						
C3											P	P						
C4											P	P						
A1					P	P												
A2					P	P												
A3					P	P												
A4					P	P												

**Note:**

- 1) +/- denotes the Positive/Negative polarity of the output voltage.
- 2) In the table: 'P' represents 'PASS'; 'F' represents 'FAIL'.

**4.3.5 PHOTO(S) SHOWN THE LOCATION(S) OF ESD EVALUATED**

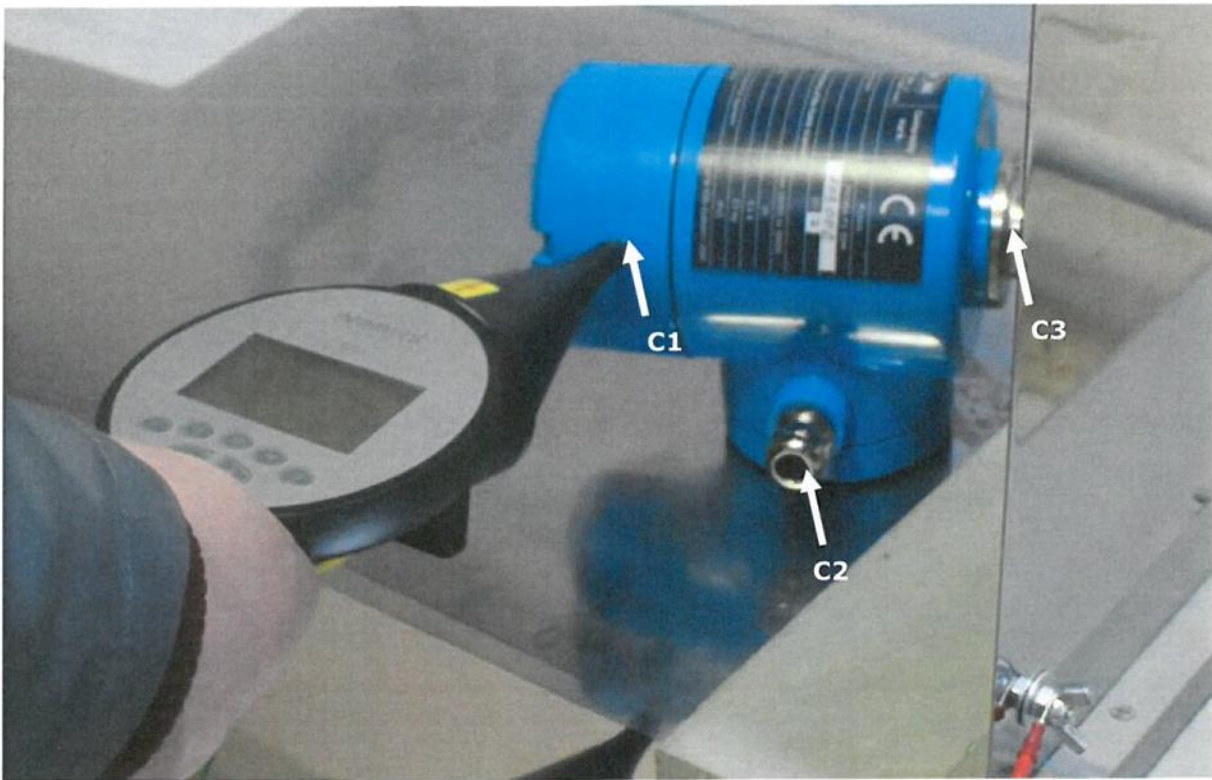

## 4.4 RS TESTING

### 4.4.1 TEST SPECIFICATION

Basic Standard:	EN 61000-4-3		
Required Performance:	A		
Frequency Range:	80 MHz - 1000 MHz	Field Strength:	10 V/m
Frequency Range:	1400 MHz - 2000 MHz	Field Strength:	3 V/m
Frequency Range:	2000 MHz - 2700 MHz	Field Strength:	1 V/m
Modulation:	1kHz Sine Wave, 80%, AM Modulation		
Frequency Step:	1 % of fundamental		
Polarity of Antenna:	Horizontal and Vertical		
Test Distance:	3 m		
Antenna Height:	1.5 m		
Dwell Time:	3 seconds		

### 4.4.2 TEST PROCEDURE

The EUT and support equipment, which are placed on a table that is 0.8 meter above ground and the testing was performed in a open area.

The testing distance from antenna to the EUT was 3 meters.

The other condition as following manner:

- a. The frequency range is swept from 80 MHz to 1000 MHz, 1400MHz - 2000MHz & 2000MHz - 2700MHz with the signal 80%amplitude modulated with a 1kHz sine wave. The rate of sweep did not exceed  $1.5 \times 10^{-3}$  decade/s. Where the frequency range is swept incrementally, the step size was 1% of fundamental.
- b. Sweep Frequency 900 MHz, with the Duty Cycle:1/8 and Modulation: Pulse 217 Hz(if applicable)
- c. The dwell time at each frequency shall be not less than the time necessary for the EUT to be able to respond.
- d. The test was performed with the EUT exposed to both vertically and horizontally polarized fields on each of the four sides.

### 4.4.3 TEST SETUP

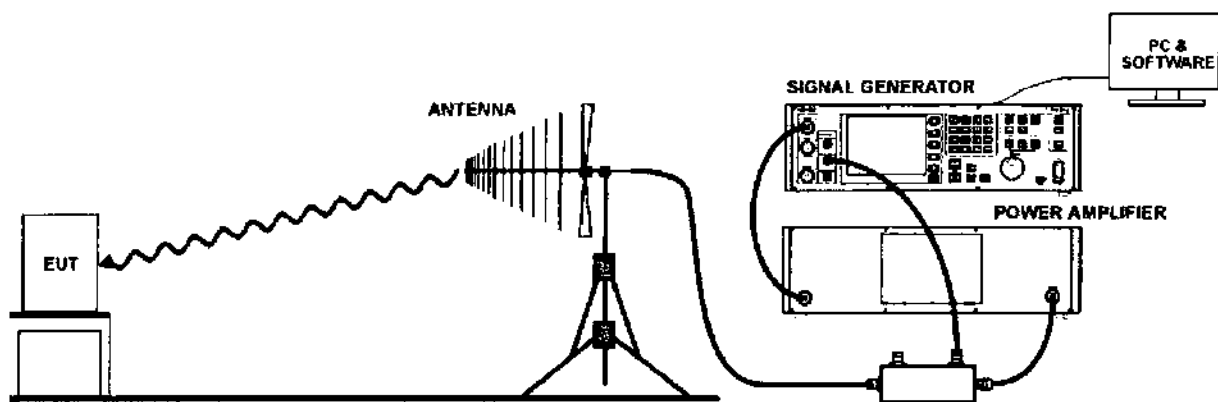

Note:

#### TABLE-TOP EQUIPMENT

The EUT installed in a representative system as described in section 7 of IEC/EN 61000-4-3 was placed on a non-conductive table 0.8 meters in height. The system under test was connected to the power and signal wire according to relevant installation instructions.

#### FLOOR-STANDING EQUIPMENT

The EUT installed in a representative system as described in section 7 of IEC/EN 61000-4-3 was placed on a non-conductive wood support 0.1 meters in height. The system under test was connected to the power and signal wire according to relevant installation instructions.

### 4.4.4 TEST RESULTS

EUT:	Flame sensor	Model Name:	PROMA-FS-03M
Temperature:	17°C	Relative Humidity:	62%
Pressure:	99 kPa	Date:	09.10.2017
Test Voltage:	DC 27 V		

Frequency Range (MHz)	RF Field Position	R.F. Field Strength	Azimuth	Perform. Criteria	Results	Judgment
80 - 1000	H / V	10 V/m (r.m.s) AM Modulated 1000Hz, 80%	Front	A	P	Complies
			Rear			
			Left			
			Right			
1400 - 2000	H / V	3 V/m (r.m.s) AM Modulated 1000Hz, 80%	Front	A	P	Complies
			Rear			
			Left			
			Right			
2000 - 2700	H / V	1 V/m (r.m.s) AM Modulated 1000Hz, 80%	Front	A	P	Complies
			Rear			
			Left			
			Right			

Note:

- 1) In the table: 'P' represents 'PASS'; 'F' represents 'FAIL'.

## 4.5 EFT/BURST TESTING

### 4.5.1 TEST SPECIFICATION

Basic Standard:	EN 61000-4-4
Required Performance:	B
Test Voltage:	Power Line:0.5 kV, 1 kV, 2kV Signal/Control Line:0.5 kV, 1kV
Polarity:	Positive & Negative
Impulse Frequency:	5kHz
Impulse Wave shape :	5/50 ns
Burst Duration:	15 ms
Burst Period:.	300 ms
Duration:	Not less than 1 min.

### 4.5.2 TEST PROCEDURE

The EUT and its simulators were placed on a ground reference plane and were insulated from it by a wood support 0.1m + 0.01m thick. The ground reference plane was 1m\*1m metallic sheet with 0.65mm minimum thickness. The other condition as following manner:

- a. The length of power cord between the coupling device and the EUT should not exceed 1 meter.
- b. Both positive and negative polarity discharges were applied.
- c. The duration time of each test sequential was 1 minute



### 4.5.3 TEST SETUP

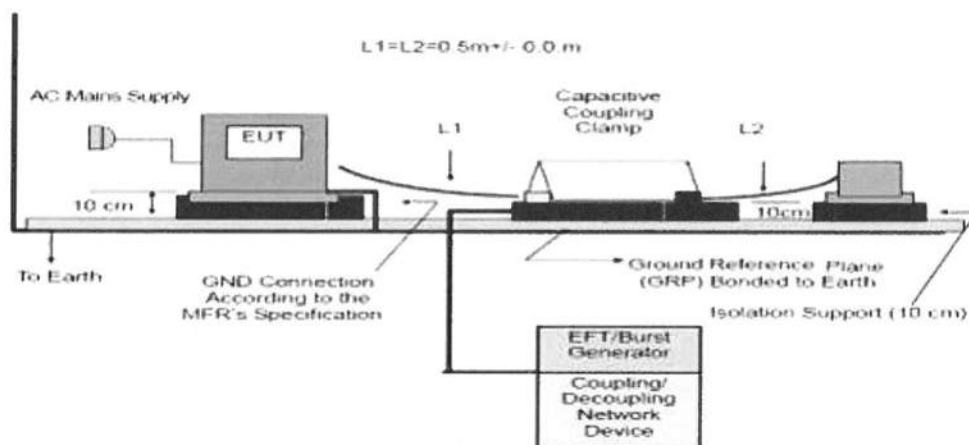
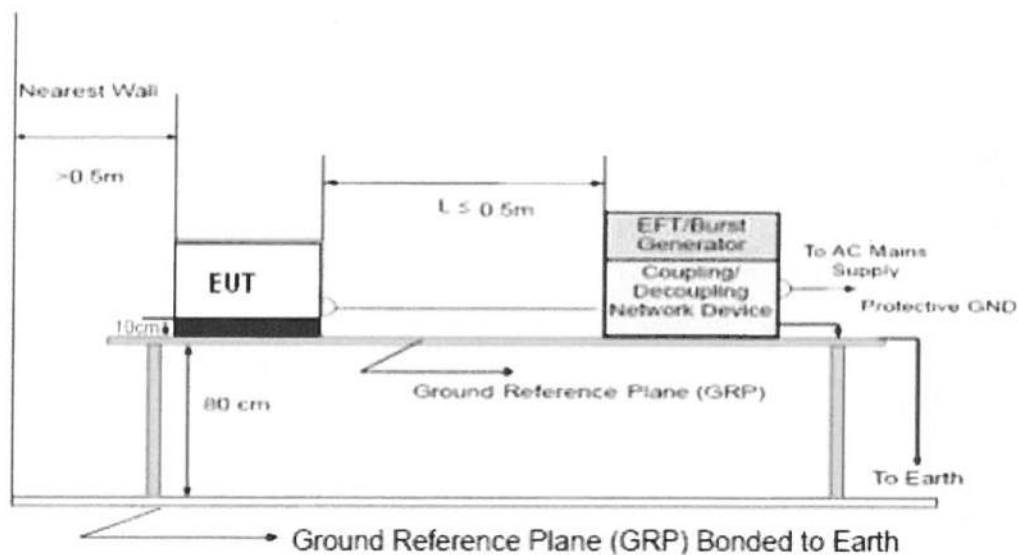

#### Note:

##### TABLE-TOP EQUIPMENT

The configuration consisted of a wooden table (0.8m high) standing on the Ground Reference Plane. The GRP consisted of a sheet of aluminum (at least 0.25mm thick and 2.5m square) connected to the protective grounding system. A minimum distance of 0.5m was provided between the EUT and the walls of the laboratory or any other metallic structure.

##### FLOOR-STANDING EQUIPMENT

The EUT installed in a representative system as described in section 7 of IEC/EN 61000-4-4 and its cables, were isolated from the Ground Reference Plane by an insulating support that is 0.1-meter thick. The GRP consisted of a sheet of aluminum (at least 0.25mm thick and 2.5m square) connected to the protective grounding system.

#### 4.5.4 TEST RESULTS

EUT:	Flame sensor	Model Name:	PROMA-FS-03M
Temperature:	17°C	Relative Humidity:	62%
Pressure:	99 kPa	Date:	09.10.2017
Test Voltage:	DC 27 V		

Coupling Line		Test level (kV)								Criterion	Result
		0.5		1		2		4			
		+	-	+	+	-	+	-	+		
AC Line	L									B	
	N										
	PE										
	L+N										
	L+PE										
	N+PE										
	L+N+PE										
DC Line		P	P	P	P	P	P				Complies
Signal Line		P	P	P	P						Complies

Note:

- 1) +/- denotes the Positive/Negative polarity of the output voltage.
- 2) In the table: 'P' represents 'PASS'; 'F' represents 'FAIL'.

## 4.6 SURGE TESTING

### 4.6.1 TEST SPECIFICATION

Basic Standard:	EN 61000-4-5
Required Performance:	B
Wave-Shape:	Combination Wave 1.2/50 us Open Circuit Voltage 8 /20 us Short Circuit Current
Test Voltage:	Power Line:0.5 kV, 1 kV, 2 kV
Generator Source:	2 ohm between networks
Impedance:	12 ohm between network and ground
Polarity:	Positive & Negative
Phase Angle:	---
Pulse Repetition Rate:	1 time / min. (maximum)
Number of Tests:	5 positive and 5 negative at selected points

### 4.6.2 TEST PROCEDURE

- a. For EUT power supply:  
The surge is to be applied to the EUT power supply terminals via the capacitive coupling network. Decoupling networks are required in order to avoid possible adverse effects on equipment not under test that may be powered by the same lines, and to provide sufficient decoupling impedance to the surge wave. The power cord between the EUT and the coupling/decoupling networks shall be 2meters in length (or shorter).
- b. For test applied to unshielded unsymmetrically operated interconnection lines of EUT:  
The surge is applied to the lines via the capacitive coupling. The coupling /decoupling networks shall not influence the specified functional conditions of the EUT. The interconnection line between the EUT and the coupling/decoupling networks shall be 2 meters in length (or shorter).
- c. For test applied to unshielded symmetrically operated interconnection /telecommunication lines of EUT:
- d. The surge is applied to the lines via gas arrestors coupling. Test levels below the ignition point of the coupling arrester cannot be specified. The interconnection line between the EUT and the coupling/decoupling networks shall be 2 meters in length (or shorter).

### 4.6.3 TEST SETUP

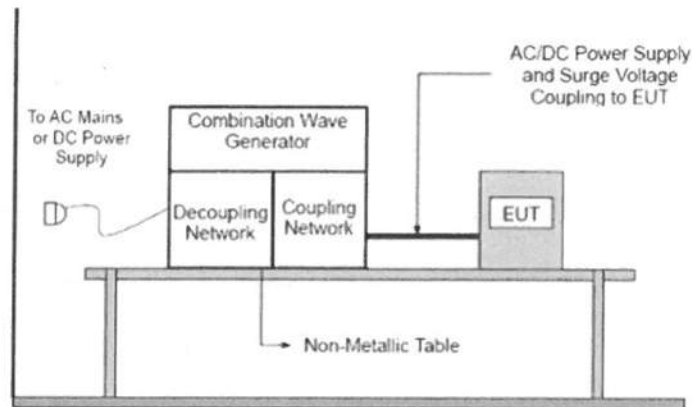

### 4.6.4 TEST RESULTS

EUT:	Flame sensor	Model Name:	PROMA-FS-03M
Temperature:	17°C	Relative Humidity:	62%
Pressure:	99 kPa	Date:	09.10.2017
Test Voltage:	DC 27 V		

Coupling Line			Test level (kV)								Criterion	Result
			0.5		1		2		4			
			+	-	+	+	-	+	-	+		
AC Line	L-N	0°									B	
		90°										
		180°										
		270°										
	L-PE	0°										
		90°										
		180°										
		270°										
	N-PE	0°										
		90°										
		180°										
		270°										
DC Line	+/-	P	P	P	P					Complies		
	+ /PE	P	P	P	P	P	P			Complies		
	- /PE	P	P	P	P	P	P			Complies		
Signal Line												

Note:

- 1) Polarity and Numbers of Impulses: 5 Pst / Ngt at each tested mode
- 2) In the table: 'P' represents 'PASS'; 'F' represents 'FAIL'; 'PE' represents 'Ground'

## 4.7 INJECTION CURRENT TESTING

### 4.7.1 TEST SPECIFICATION

Basic Standard:	EN 61000-4-6
Required Performance:	A
Frequency Range:	0.15 MHz - 80 MHz
Field Strength:	3 Vr.m.s.
Modulation:	1kHz Sine Wave, 80%, AM Modulation
Frequency Step:	1 % of fundamental
Dwell Time:	3 seconds

### 4.7.2 TEST PROCEDURE

The EUT are placed on an insulating support 0.1m high above a ground reference plane. CDN (coupling and decoupling device) is placed on the ground plane about 0.3m from EUT. Cables between CDN and EUT are as short as possible, and their height above the ground reference plane shall be between 30 and 50mm (where possible). The disturbance signal described below is injected to EUT through CDN.

The other condition as following manner:

- The frequency range is swept from 150 kHz to 80 MHz, with the signal 80% amplitude modulated with a 1kHz sine wave. The rate of sweep did not exceed  $1.5 \times 10^{-3}$  decade/s. Where the frequency range is swept incrementally, the step size was 1% of fundamental.
- The dwell time at each frequency shall be not less than the time necessary for the EUT to be able to respond.

### 4.7.3 TEST SETUP

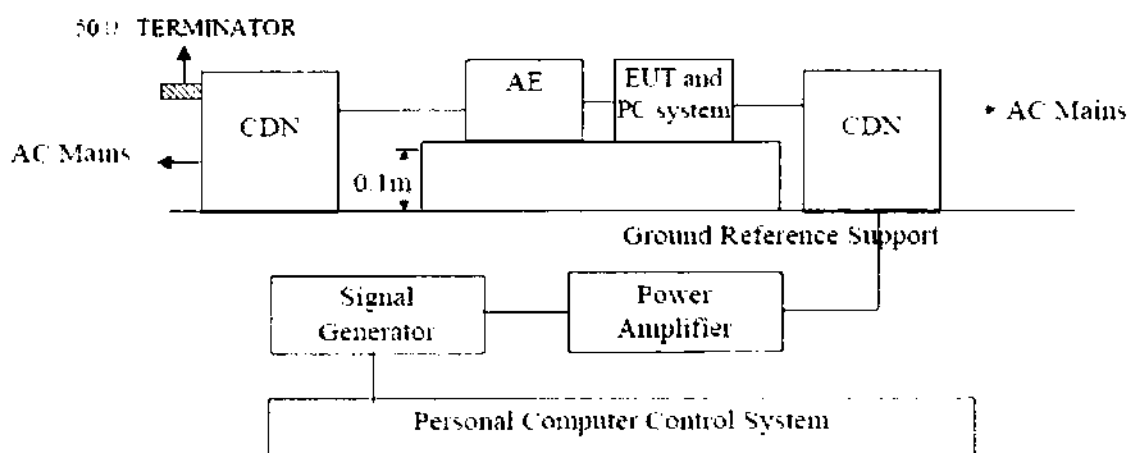

#### NOTE:

#### FLOOR-STANDING EQUIPMENT

The equipment to be tested is placed on an insulating support of 0.1 meters height above a ground reference plane. All relevant cables shall be provided with the appropriate coupling and decoupling devices at a distance between 0.1 meters and 0.3 meters from the projected geometry of the EUT on the ground reference plane.

#### 4.7.4 TEST RESULTS

EUT:	Flame sensor	Model Name:	PROMA-FS-03M
Temperature:	17°C	Relative Humidity:	62%
Pressure:	99 kPa	Date:	09.10.2017
Test Voltage:	DC 27 V		

Test Ports (Mode)	Freq. Range (MHz)	Field Strength	Perform. Criteria	Results	Judgment
Input/ Output AC. Power Port	0.15 - 80	3V(r.m.s) AM Modulated 1000Hz, 80%	A	N/A	N/A
Input/ Output DC. Power Port	0.15 - 80		A	P	Complies
Signal Line	0.15 - 80		A	N/A	N/A

Note:

- 1) N/A - denotes test is not applicable in this Test Report.
- 2) In the table: 'P' represents 'PASS'; 'F' represents 'FAIL'.

## 4.8 POWER FREQUENCY MAGNETIC FIELD TESTING

### 4.8.1 TEST SPECIFICATION

Basic Standard:	EN 61000-4-8
Required Performance:	A
Frequency Range:	50 Hz
Field Strength:	30 A/m
Observation Time:	1 minute
Inductance Coil:	Rectangular type, 1mx1m

### 4.8.2 TEST PROCEDURE

The EUT and support equipment, are placed on a table that is 0.8 meter above a metal ground plane measured 1m\*1m min. and 0.65mm thick min.

The other condition as following manner:

- The equipment cabinets shall be connected to the safety earth directly on the GRP via the earth terminal of the EUT.
- The cables supplied or recommended by the equipment manufacturer shall be used. 1 meter of all cables used shall be exposed to the magnetic field.

### 4.8.3 TEST SETUP

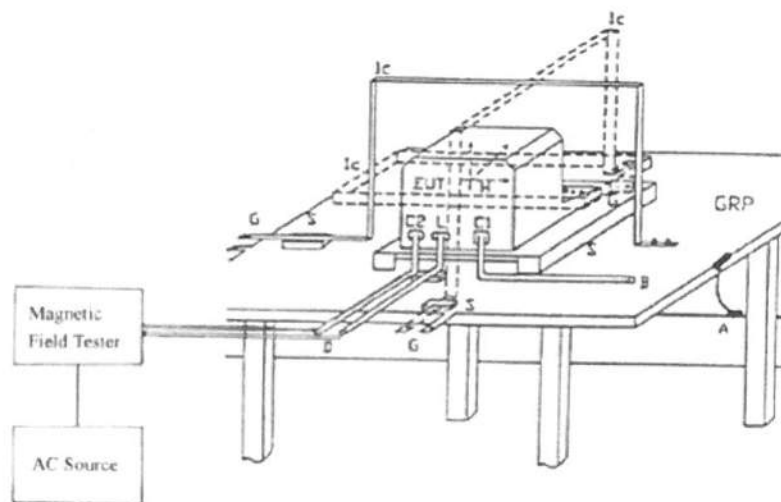

Note:

#### TABLE-TOP EQUIPMENT

The equipment shall be subjected to the test magnetic field by using the induction coil of standard dimension (1 m x 1 m). The induction coil shall then be rotated by 90 degrees in order to expose the EUT to the test field with different orientations.

#### FLOOR-STANDING EQUIPMENT

The equipment shall be subjected to the test magnetic field by using induction coils of suitable dimensions. The test shall be repeated by moving and shifting the induction coils, in order to test the whole volume of the EUT for each orthogonal direction. The test shall be repeated with the coil shifted to different positions along the side of the EUT, in steps corresponding to 50 % of the shortest side of the coil. The induction coil shall then be rotated by 90 degrees in order to expose the EUT to the test field with different orientations.

#### 4.8.4 TEST RESULTS

EUT:	Flame sensor	Model Name:	PROMA-FS-03M
Temperature:	17°C	Relative Humidity:	62%
Pressure:	99 kPa	Date:	09.10.2017
Test Voltage:	DC 27 V		

Test Mode	Test Level	Antenna aspect	Duration (s)	Perform. Criteria	Results	Judgment
Enclosure	30 A/m	X	60 s	A	P	Complies
Enclosure	30 A/m	Y	60 s	A	P	
Enclosure	30 A/m	Z	60 s	A	P	



Note:

- 1) In the table: 'P' represents 'PASS'; 'F' represents 'FAIL'.



## 5 EUT PHOTO



<b>Manufacturer:</b>	 NPP "PROMA" LLC Tukaya str. 125, 420054, Kazan	<b>Conformity mark:</b>	
<b>Manufacturing country:</b>	Russia		
<b>Name and designation of the flame scanner:</b>	PROMA-FS-03M		
<b>Serial number:</b>	XXXXXXXXXX		
<b>Year and month of manufacture:</b>	201 <input checked="" type="checkbox"/> -07- <input checked="" type="checkbox"/>		
<b>Characteristics of the flame scanner</b>			
<b>Operating supply voltage:</b>	from 24VDC to 30VDC		
<b>Current type:</b>	DC		
<b>Consumption current, no more then:</b>	0,4 A		
<b>Product weight:</b>	2.5 kg		
<b>Designation of the protection degree of electrical equipment:</b>	IP65		
<b>Designation of the technical specification:</b>	TS 4218-035-0480601-2007		

end of test report